



Product Type
Thermal Circuit Breaker

Product Series
CTB-Series

Description
[CTB-Series PDF eLibrary](#) ↓

The CTB-Series is a compact, single pole, rocker actuated family of thermal circuit breakers designed to protect equipment. Utilizing simple, precision design with few moving parts, these breakers offer cost effective, extremely reliable circuit protection with high resistance against

shock and vibration. They are ideally suited for such applications as household and commercial appliances, transportation, marine, telecommunications, power strips, audio-visual, medical, power supplies, and exercise equipment.

Series PDF eLibrary	<ul style="list-style-type: none"> CTB-Series Thermal Cir. Breaker PDF (113.6 KB)
Certifications	UL, CUL, TUV, CE
Number of Poles	1 pole
Maximum Current and Voltage Ratings	3 - 16 amps @ 125-250VAC, 50VDC
Maximum Interrupting Capacity	1,000 amps
Available Circuits	Series Trip
Actuator Style	Rocker actuator
Terminal Options	.250 Quick Connect Tabs
Mounting Method	Front Panel Snap-in

Thermal Circuit Protectors

Reliable, Cost-effective Circuit Protection

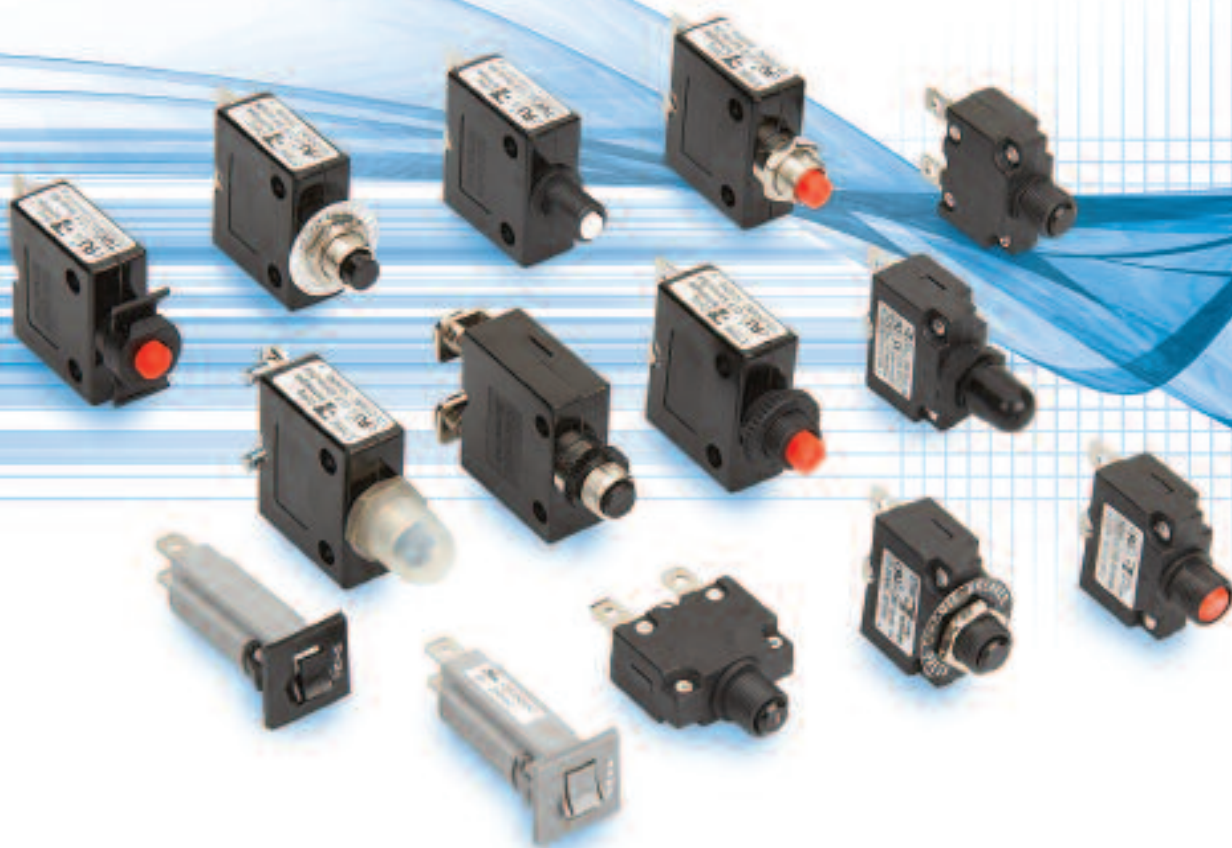

Any electrical or electronic equipment that is designed without including circuit protection is an accident waiting to happen. Under normal operating conditions, this may not appear to be a problem. However, normal operating conditions are not always guaranteed. Under strained or heavy use, a motor and/or another load-generating component within the equipment will draw additional current from the power source; when this happens, the equipment's wires and/or components will overheat and may ultimately burn up. Also, power surges and short circuits in unprotected equipment can cause extensive damage to the equipment and to the conductors leading to the equipment.

In addition to protecting the equipment, the entire electrical system including the control switches, wires, and power source must be protected from faults. A circuit protection device should be employed at any point where a conductor size changes. Many electronic circuits and components like transformers have a lower overload withstand threshold level than conductors such as wires and cables. These components require circuit protection devices featuring very fast overload sensing and opening capabilities.

Specifying a circuit protection device for an application is not a difficult task, but it will require some thought. If electrical and electronic equipment is designed with over-specified circuit protection devices they will be vulnerable to the damaging effects of power surges and the catastrophic results of a fire; while using under-specified circuit protection devices will result in nuisance tripping.

The short circuit capacity of a circuit protection device should be greater than the circuit's available short circuit fault current. Available short circuit current is the maximum RMS current that would be present if all the conductors were to be connected directly to the fault location. In reality, this is not the case. The actual short circuit current is much less than the available short circuit current. The actual short circuit current is reduced due to the combined impedance of the conductors, the size of the transformer and other current restricting components within the circuit.

The application's environmental conditions must be considered when selecting the proper circuit protection device. Excessive temperature, humidity, severe vibration and shock can cause adverse performance characteristics in many types of circuit protection devices. For instance, a fuse element is less reliable when it is hot than when it is cold.

Available Choices of Circuit Protection

Carling Technologies offers three types of circuit protection devices: thermal circuit protectors, hydraulic/magnetic circuit protectors/breakers and equipment leakage circuit breakers. This catalog features our thermal circuit protection product line. For details related to hydraulic/magnetic circuit protection and equipment leakage circuit breaker products, please see our Circuit Protection 403 catalog.

Thermal circuit protectors utilize a bimetallic strip electrically in series with the circuit. The heat generated by the current during an overload deforms the bimetallic strip and trips the breaker. Thermal protectors have a significant advantage over fuses in that they can be reset after tripping. They can also be used as the main ON/OFF switch for the equipment being protected.

Hydraulic/magnetic circuit protectors/breakers provide highly precise, reliable and cost effective solutions to most design problems. The hydraulic/magnetic circuit breaker is considered to be temperature stable and thus is not appreciably affected by changes in ambient temperature. Its over-current sensing mechanism reacts only to changes of current in the circuit being protected. It has no "warm-up" period to slow down its response to overload. It has no "cool-down" period after overload before it can be reset. The characteristics of a

hydraulic/magnetic circuit breaker can be tailored in four separate areas: the desired circuit; the trip point (in amperes); the time delay (in seconds); and the inrush handling capacity of the breaker. These factors can be varied with relatively little impact on the short circuit capability of the breaker. Typically, hydraulic/magnetic circuit breakers are available with a choice of three different trip time, delay curves: slow, medium and long. These choices provide the designer with a high level of design flexibility when matching the breakers trip time delay curves to other circuit protection devices in a cascade, or discriminating circuit. In addition, special hi-inrush constructions are available for equipment with severe inrush characteristics.

Equipment leakage circuit breakers function as hydraulic/magnetic circuit breakers, offering customized overload and short circuit protection. In addition, they sense and guard against faults to ground using innovative electronics technologies. With the exception of small amounts of leakage, the current returning to the power supply will be equal to the current leaving the power supply. If the difference between the current leaving and returning through the earth leakage circuit breaker exceeds the leakage sensitivity setting, the breaker trips and its LED illuminates. The LED gives a clear indication that the trip occurred as a result of leakage to ground. This protection helps prevent serious equipment damage and fire.

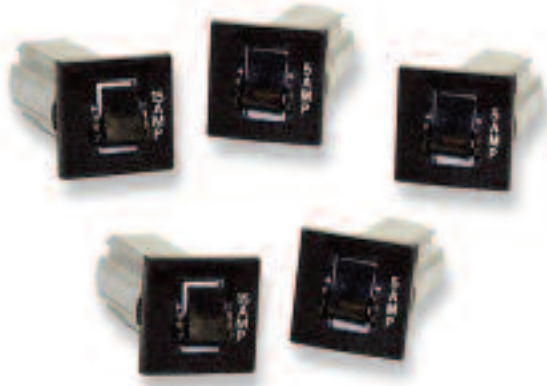

Rating:
3 to 16A, 125, 250VAC, 50VDC

Approvals:
UL, CUL, VDE, CE

Interrupting capacity:
1000 amps

Insulation Resistance:
100M ohms

Applications:
Household Appliances
Transportation
Marine
Power Strips
Medical Equipment
Audio Visual Equipment
Power Supplies
Exercise Equipment

ROHS Compliant

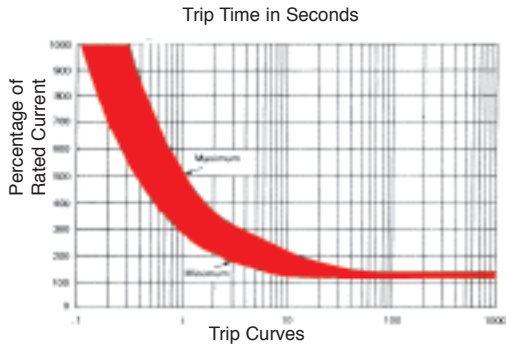

CORRECTION FACTOR ¹	
0°C	x .67
10°C	x .72
15°C	x .83
18°C	x .87
25°C	x 1.00
32°C	x 1.05
40°C	x 1.18
50°C	x 1.33
60°C	x 1.67

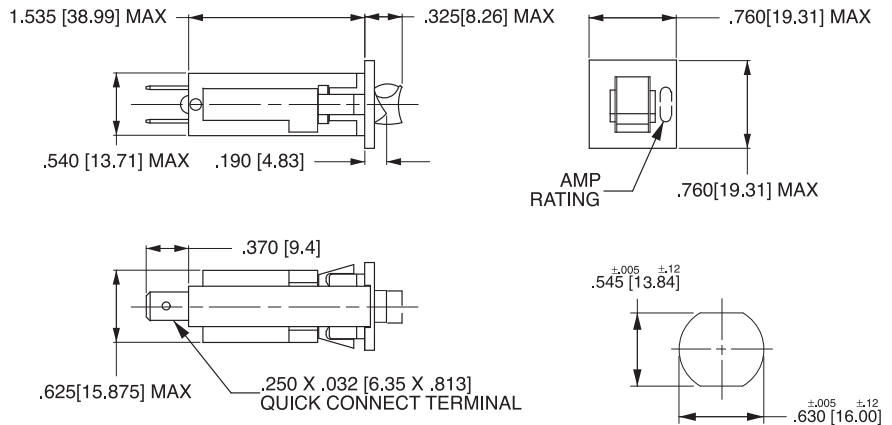

RECOMMENDED PANEL THICKNESS:
.032 - .062 [.81-1.57]

DOUBLE D MOUNTING

1. To adjust the breaker rating for ambient temperature, multiply the breaker rating by the factor. (ex: 5A rating x .850 = 4.25A. Select 4A rating.)

CTB - B - B - 05 - B

¹ Series
Series

² Bezel Color
Bezel Color

³ Rocker Color
Rocker Color

⁴ Rating
Rating

⁵ Panel Thickness
Panel Thickness

1 SERIES
CTB

2 BEZEL COLOR¹
B Black

3 ROCKER COLOR¹
B Black

4 RATING

03	3 amp	08	8 amp	14	14 amp
04	4 amp	09	9 amp	15	15 amp
05	5 amp	10	10 amp	16	16 amp
06	6 amp	12	12 amp		
07	7 amp	13	13 amp		

5 PANEL THICKNESS

blank fits standard thickness of .032 - .062
B fits .070 - .110 panel thickness

NOTES:

All dimensions are in inches [millimeters].
Tolerance ±.005 [.127] unless otherwise specified.
Breaker must hold 100% of rated current and must trip at 150% and above, within the time limits shown in curve.
Trip times specified at 25° ambient with no preloading.
¹ Additional colors available. Consult factory.

Most countries have regulatory agencies that determine the safety and performance standards required for products used in that country. Carling Technologies' circuit breakers are tested and have been certified by the most widely recognized of these agencies including Underwriters Laboratories (UL) in the United States; Canadian Standards Association (CSA) in Canada; TUV Rheinland/Berlin-Brandenburg (TUV) and Verband Deutscher Elektrotechniker (VDE) in Germany.

UL Recognized/UL1077 Recognized

UL Recognition covers components, which are incomplete or restricted in performance capabilities. These components will later be used in complete end products or systems Listed by UL. These Recognized components are not intended for separate installation in the field, they are intended for use as components of complete equipment submitted for investigation to UL.

Carling Technologies offers circuit breakers which are classified as supplementary circuit protectors and are Recognized under the UL Components Recognition Program as Protectors, Supplementary, UL Standard 1077. A UL 1077 Recognized supplementary circuit protector must have a Listed overcurrent device as a "back up".

UL Listed/UL 489 Listed

UL Listing indicates that samples of the circuit breaker as a complete product have been tested by UL to nationally recognized safety standards and have been found to be free from reasonably foreseeable risks of fire, electric shock and related hazards, and that the product was manufactured under UL's Follow-Up Services program.

Carling Technologies offers branch circuit breakers that are UL 489 Listed. Branch circuit breakers are classified as a final overcurrent device dedicated to protecting the branch circuit and outlet(s). They do not require an additional "back up" overcurrent device wired in series to protect a circuit. Carling's C, E and F-Series circuit breakers offer UL489 Listing. In addition, they are UL489A Listed for the Telecom industry.

UL1500 (MARINE)

UL1500 refers to products and components classified as ignition-protected, and are intended to be installed and used in accordance with applicable requirements to the U.S. Coast Guard, the Fire Protection Standard for Pleasure and Commercial Motor Craft, ANSI/NFPA No. 302, and the American Boat and Yacht Council, Incorporated.

CSA

The CSA (Canadian Standards Association) is the closest in concept and nature to UL of any group outside of the United States. Their standards and requirements are often almost identical to corresponding UL standards. CSA publishes their standards for most circuit protection devices as separate sections of CSA Standard C22.2 that in turn, forms a part of the Canadian Electrical Code.

CUL

A CUL mark on a product means that samples of the product have been evaluated to the applicable Canadian standards and codes by Underwriters Laboratories Inc.

VDE and TUV

There are two German government approved independent agencies, VDE (Verband Deutscher Elektrotechniker), and TUV (Technischer Überwachungs-Verein). In the circuit protection field, outside of the U.S.A. and Canada, VDE is the best known certification mark. VDE testing facilities are located in Germany.

TUV also performs testing and grants certification in accordance to the IEC/EN specifications. TUV's organization is made up of at least eleven geographically dispersed companies. At least two are located in the United States. This aids some U.S. manufacturers in getting "fast track" approval to a IEC/EN specifications.

CE MARKING

The European Union's (EU) approach to create single market access is based on four principles: harmonized directives, harmonized standards, harmonized conformity assessment procedures and CE marking. The CE marking is affixed to products indicating that the product conforms to relevant directives and standards. Various directives and standards contain the requirements for the CE marking. The CE marking is primarily for market control by custom inspectors.

Before a manufacturer can affix the CE marking to their product they must complete the following steps:

1. Identify the applicable EU directive/standard
2. Perform the conformity assessment according to the applicable EU directive/standard
3. Establish a Technical File containing test reports, documentation, certificates, etc.
4. Prepare and sign a EU Declaration of Conformity

Many of Carling Technologies' circuit protection products are available with CE marking indicating conformance to Low Voltage Directive 73/23/EEC.